

# Installation Guide for UHF & Cellular Combo Smart Antennas

Model numbers: ANMA1103AU, ANMA1104AU

Zetifi strongly recommends professional installation of all Smart Antenna products by a qualified automotive electrician.

Failure to do so presents a safety risk and may result in less-than-optimal antenna performance.

Please contact our support team for further assistance on the install and operation of your Zetifi Smart Antenna:

 **1300 093 711** (Monday to Friday, 9am - 5pm AEST/AEDT)

 **support@zetifi.com**



In the box
1 x UHF & Cellular Combo Smart Antenna
1 x Zetifi 22mm antenna installation tool
1 x battery cable
1 x extension coaxial cable to UHF CB radio (FME M to F)
1 x extension coaxial cable to cellular device (SMA M to F)
1 x conduit to protect external cables

Tools & resources required
Smartphone with Zetifi Smart Antenna app
Torque wrench
Spanner kit to suit 8mm and 22mm nuts
Cable ties
Electrical tape
Heat gun

## Wiring Diagram

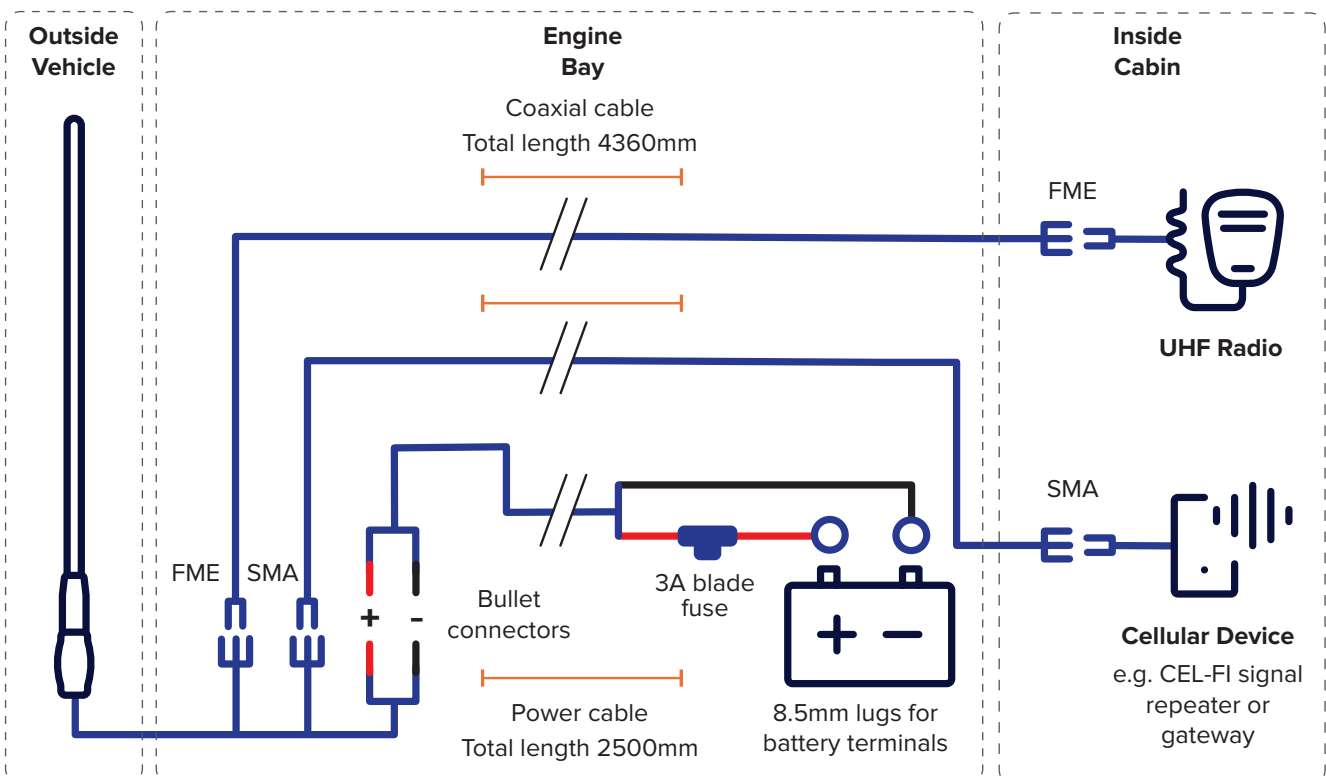

## Installation Steps

### 1 Install antenna on bullbar mount

**Tools required:** Zetifi antenna installation tool (supplied), torque wrench, 22mm spanner.

- Remove plastic cable protector at bottom of antenna by unscrewing.
- Ensure Nordlock washer supplied is between bracket and nut before securing in place.
- Use provided antenna installation tool to allow use of torque wrench set to 85 Nm to complete antenna attachment.



### 2 Connect cellular extension coaxial cable to booster and route to antenna

**Tools required:** 8mm spanner, torque wrench, cable ties.

Run coax cable from your device through the vehicle's engine bay and leave SMA connections loose close to antenna.

- Ensure SMA connectors to your device (CEL-FI booster or gateway) are tightened to 0.4 Nm.
- Minimise excessive cable run.
- Avoid tight turns that could damage cable (no less than 25mm diameter turns).
- Secure cable in place with cable ties.



### 3 Connect UHF extension coaxial cable to UHF radio and route to antenna

**Tools required:** 8mm spanner, torque wrench, cable ties.

Follow the same steps and guidance as above to run extension coaxial cable from your UHF radio through the vehicle's engine bay and leave FME connections loose close to antenna.



### 4 Connect battery cable to vehicle battery and route to antenna

**Tools required:** Spanners, torque wrench, cable ties.

Connect lugs to battery terminals and run battery cable to antenna. Leave bullet connectors loose at antenna.

- Ensure positive and negative are correctly matched using cable colour, i.e. red to red, black to black.
- Carefully secure and protect cable using cable ties and insulation if required to avoid contact with heat sources.

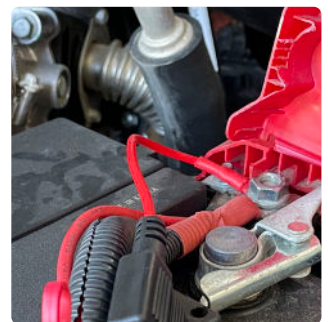
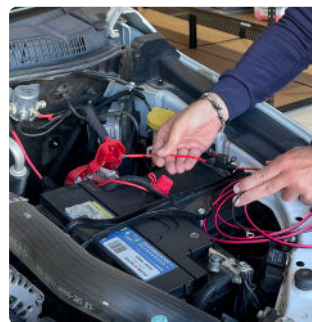

## 5 Connect battery and coax cables to antenna

**Tools required:** 8mm spanner, 8mm torque wrench, heat shrink (supplied), heat gun, conduit.

- Remove heat shrink and place over cable connections for SMA and FME connections on coax cable. Don't shrink until you're sure it will cover SMA and FME connectors only, not the bullet connectors for battery.
- Connect the two short coax leads from antenna to longer extension coax from UHF radio and cellular device. Use torque wrench to tighten to 0.4 Nm.
- Connect bullet connectors for battery cable, taking note of positive and negative terminals, i.e. red to red, black to black.
- Use heat gun to shrink heat wrap over SMA and FME connection on coax cables, taking care to protect battery cable with your other hand.
- Cover all cable and connections external to vehicle with provided split conduit cable protector. Secure in place with electrical tape or cable ties.



## 6 Install phone app and connect to Smart Antenna

**Tools required:** Smart phone with Bluetooth®, internet access.

Download **Zetifi Smart Antenna app** and turn on Bluetooth® to connect to your antenna.

- Click on 'connection status', antenna in range should appear automatically to connect.
- If antenna doesn't appear, turn on vehicle to provide more power as low voltage cutoff setting might have turned off smart antenna.

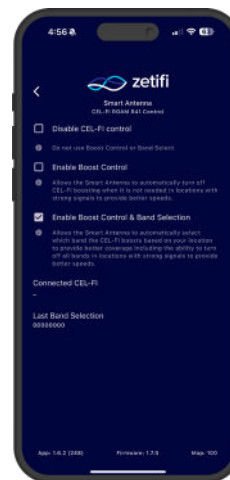

Still have more questions about the Smart Antenna installation?

Please don't hesitate to call our support team on **1300 093 711** or email [support@zetifi.com](mailto:support@zetifi.com). We're happy to help!